

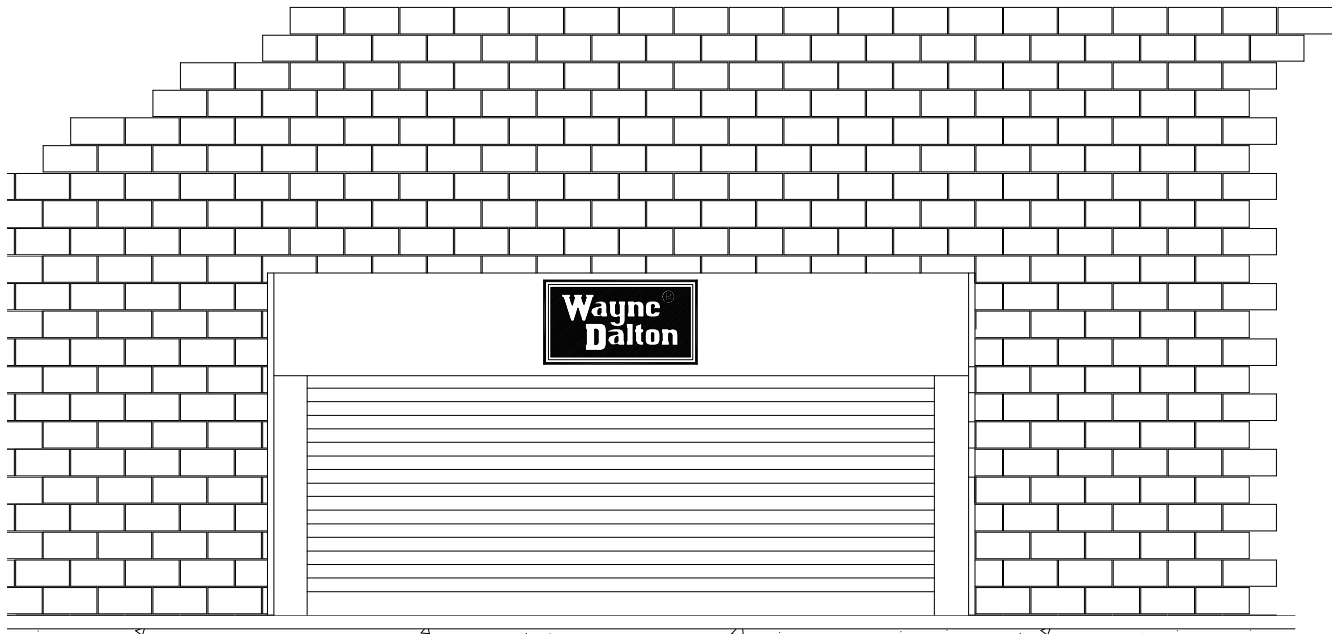

# Rolling Steel Service Doors

(900 and 800 Series, Thermo-tite™, Secur-Vent™, Titan™)

## Installation Instructions and Operation and Maintenance Manual



### **IMPORTANT NOTICE !!**

**READ THE ENCLOSED INSTRUCTION CAREFULLY BEFORE ATTEMPTING TO REMOVE EXISTING DOOR OR INSTALLING THIS SERVICE DOOR. PAY CLOSE ATTENTION TO ALL WARNING LABELS AND THE IMPORTANT SAFETY NOTICES ON THE FOLLOWING PAGE.**

**THIS MANUAL MUST BE ATTACHED TO THE WALL IN CLOSE PROXIMITY OF THE DOOR.**



# IMPORTANT SAFETY NOTICES

[Read the enclosed instructions carefully before attempting installation. If there are any questions about any of the procedures, do not perform the work. Instead, have a qualified door agency do the installation or repairs.]

1. Operate the door **ONLY** when properly adjusted and free of obstructions.
2. Door is constantly under **EXTREME SPRING TENSION**. Repairs, adjustments, installation and removal are dangerous so that such work should be performed **ONLY** by qualified door service people.
3. **DO NOT PERMIT** children to play with the door or the electrical controls. The child could get caught between the door and floor causing fatal injury..
4. If the door is now or later becomes electrically operated any locking devices **MUST** be disengaged or electrically interlocked.
5. Avoid standing in the open doorway or walking through doorway while door is moving. One could get caught between the door and floor causing fatal injury.
6. Should door become hard to operate or completely inoperative, it is recommended that a qualified door agency correct the problem to prevent any accident or injury.
7. Avoid installing door on windy days. The door could fall causing an accident or injury.
8. Frequently check all bolted connections to make sure they are secure during the lifetime of the door to prevent injuries and accidents due to loose connections.
9. To avoid injury never place hands or fingers between gears, chain or sprockets, while the door is being operated. Otherwise, broken bones or serious lacerations could occur by pinching the hands or fingers.
10. This manual is not intended to direct “take-down” procedures of existing doors. Consult your local door authority if this is required before new doors are to be installed
11. Thoroughly familiarize yourself with the construction codes required in the region where the door is to be installed before initiating work.
12. Wear the proper safety clothing and protective safety gear as needed.
13. Crew chiefs should consider using a 2-person (or larger) crew for larger doors.
14. Definition of key words used in this manual are as follows:

**⚠️ WARNING** - Indicates a potentially hazardous situation which, if not avoided, could result in serious injury or death.

**⚠️ CAUTION** - Alerts against unsafe practices and potential property damage accidents.

**IMPORTANT!** - Required step for safe and proper door operation.

**NOTE:** - Information assuring proper installation of the door.

**HINT:-** Suggested step to simplify installation based on experience.

# Wayne-Dalton Corp.

## Limited One Year Warranty

Wayne-Dalton Corp., Dalton, Ohio 44618 warrants that every door and its hardware and fittings will be free of defects in workmanship and material. Should any defect in workmanship or material appear within **ONE YEAR** of installation, Wayne-Dalton Corp. shall, upon notification, correct such non-conformity at its option, by repairing or replacing any defective part or parts.

**THIS WARRANTY GIVES YOU SPECIFIC RIGHTS WHICH VARY FROM STATE TO STATE.**

This warranty does not include normal wear, damage beyond the manufacturer's control or replacement labor.

**NO WARRANTIES EXPRESSED OR IMPLIED (INCLUDING, BUT NOT LIMITED TO, A WARRANTY OF MERCHANTABILITY OR FITNESS FOR PARTICULAR PURPOSE) SHALL EXTEND BEYOND THE APPLICABLE TIME PERIOD STATED IN BOLD FACE TYPE ABOVE.**

Claims for the defective parts must be made to the Wayne-Dalton Corp. dealer from whom the purchase was made. Notification of defects in workmanship and material must be given to the dealer within the governing warranty period.

**THE FOREGOING WARRANTY IS EXCLUSIVE AND IN LIEU OF ALL OTHER WARRANTIES. IN NO EVENT SHALL SELLER BE LIABLE FOR SPECIAL, INCIDENTAL OR CONSEQUENTIAL DAMAGES. HOWEVER, SOME STATES DO NOT ALLOW LIMITATIONS ON HOW LONG AN IMPLIED WARRANTY LASTS OR THE EXCLUSION OR LIMITATION OF INCIDENTAL OR CONSEQUENTIAL DAMAGES, SO THE ABOVE LIMITATION OR EXCLUSION MAY NOT APPLY TO YOU.**

# Rolling Steel Service Door

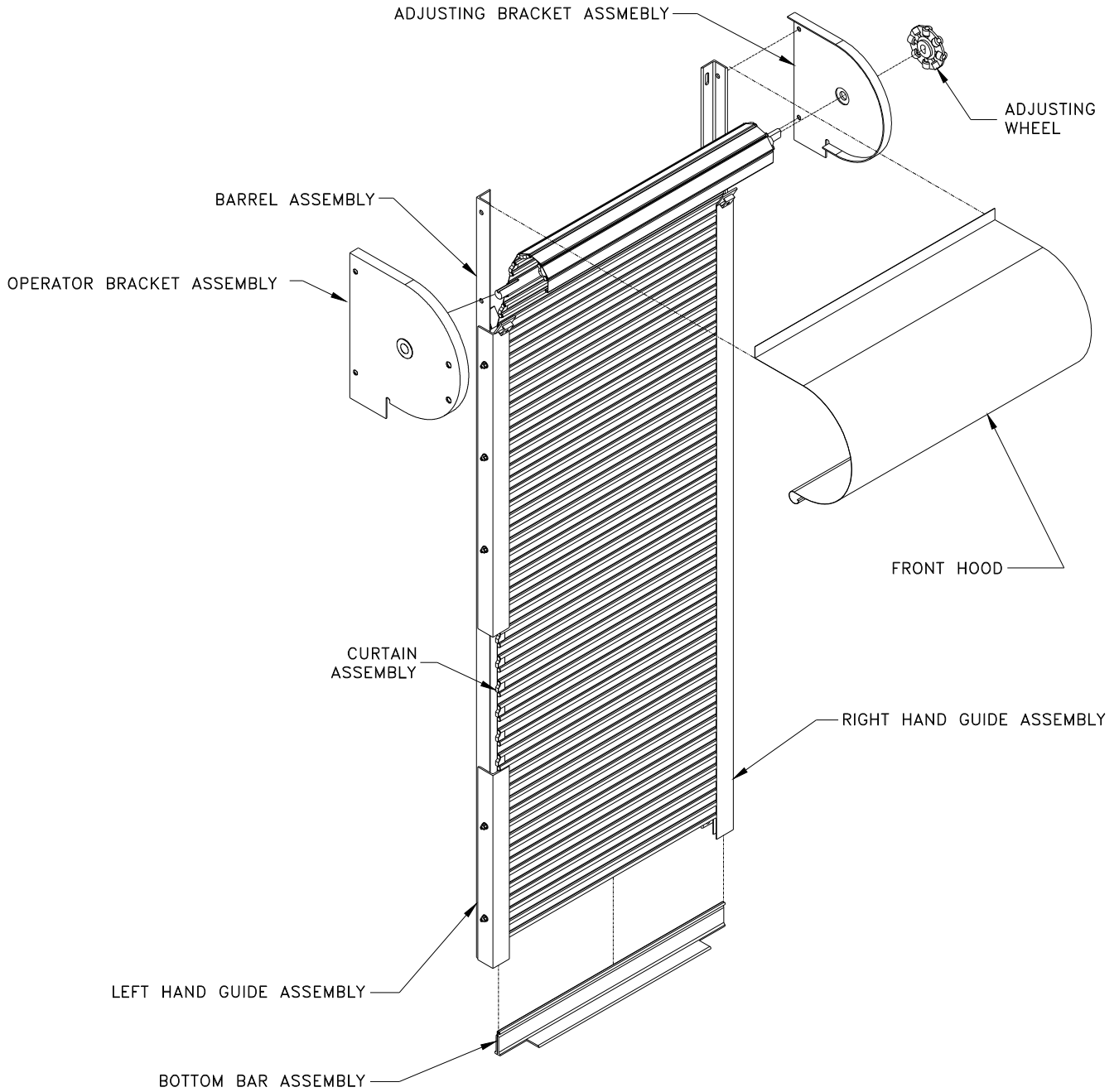

Figure # 1

# Table of Contents

	Page
About this manual.....	i
Preparation.....	i
Door components and hardware.....	ii
Step 1 : Opening checks.....	1
Step 2 : Guide mounting.....	2
Step 3 : Attach Curtain to Barrel Assembly.....	7
Step 4 : Attach Brackets to Wall Angle.....	9
Step 5 : Applying Tension.....	12
Step 6 : Testing Door Balance.....	14
Step 7 : Installing Hoods, Hood Straps & Housings.....	17
Step 8 : Miscellaneous Final Checklist.....	19
Optional Components.....	Appendix A
Service Record.....	Appendix B
Trouble Shooting.....	Appendix C
Thru-wall Power Unit Assembly.....	Appendix D
Compound Tension Adjuster Assembly.....	Appendix E
Weatherizing Instructions for Service Doors.....	Appendix F

## INTRODUCTION

This manual's main function is to assist the installer in correctly mounting doors with due regard for safety, operation, and sound construction practices. NFPA 80 and local fire and building codes take precedence with regard to any discrepancies among them.

All Wayne-Dalton rolling fire doors follow the general guidelines set forth here. Additional installation information for each door shipped is found in the packing slip and supplementary drawings. There are also bolt and small parts bags sealed separately with accessory lists describing what part goes where.

## PREPARATION

Read the installation instructions to become familiar with the names of the various components and their relation to each other. It is a necessity for the installer to determine the following:

- The type of mounting (face-of wall or between jambs).
- Method of operation (hoist, crank, motor, or push-up).
- The hand of operation determined from the coil side (right or left).
- Type of jamb (masonry or steel) on which the door guides mount and the fasteners required.
- The dimensions for the opening width, opening height, head room, and side room.

## MATERIAL

Inspect your door prior to leaving for the job site for possible damage or shortage of parts. Report any claims to your door supplier immediately.

## CLEARANCES

The installation drawings supplied in the hardware bag contain information on bracket size and head and side room for each door. Be sure that the dimensions are correct for the opening you are working on. Take special note of the "C" dimension (FIG 6). **THIS DIMENSION MUST BE HELD IN ORDER TO PREVENT INTERFERENCE WITH THE PROPER OPERATION OF THE DOOR WHILE BEING CLOSED.** Be sure the required clearances are available prior to installation.

## TOOLS

The tools recommended for proper installation of each door will vary, but commonly used tools are:

- Electric drill with 3/8" or 1/2" chuck.
- Masonry drill or impact hammer and bits.
- Chain hoist and sling for raising barrel and curtain assembly.
- Ladders and scaffolding.
- Wrenches, screwdrivers, hammer, level, drills, center punch, tape measure, chalk line, visegrips or C-clamps, water-level hose.
- Two hardened steel bars, 1/2" diameter and approximately 36" long.
- Two 3/4" diameter steel rods 24" long for checking and correcting guide openings.

# Section 1 - Supplied Parts List

## Major Components and Assemblies

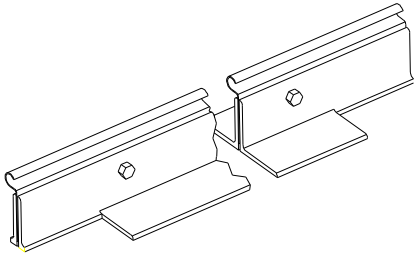

BOTTOM BAR ASSEMBLY

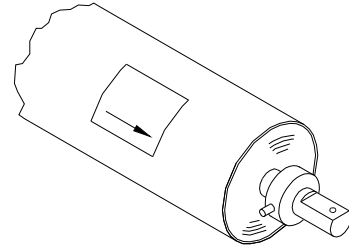

BARREL ASSEMBLY

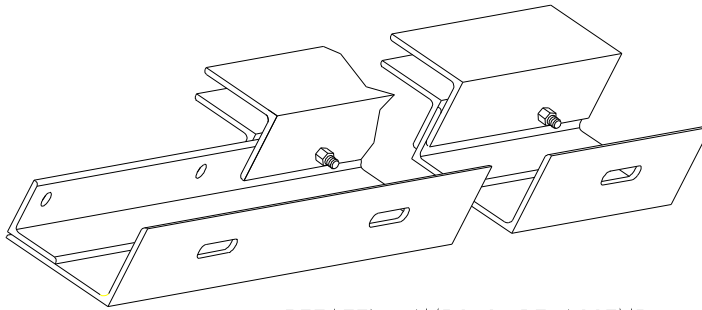

BETWEEN JAMBS GUIDE ASSEMBLY

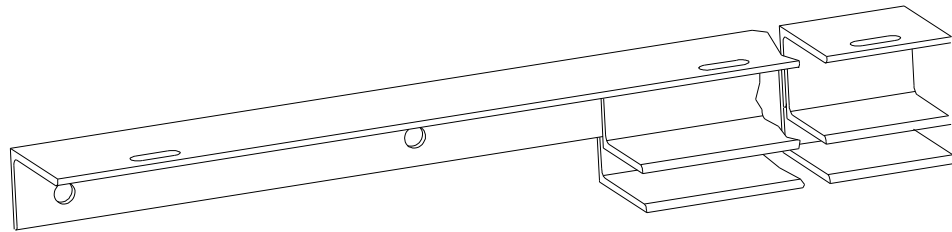

FACE MOUNTED STEEL JAMB GUIDE ASSEMBLY

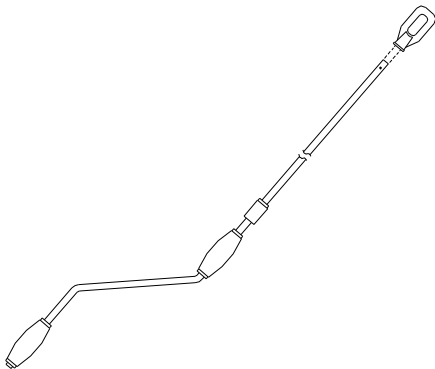

AWNING CRANK WINDING SHAFT

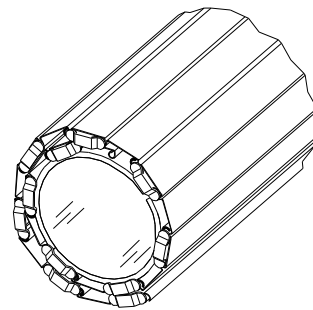

CURTAIN ASSEMBLY

# Section 2 - Supplied Parts List

## Typical Bracket Assemblies and Components

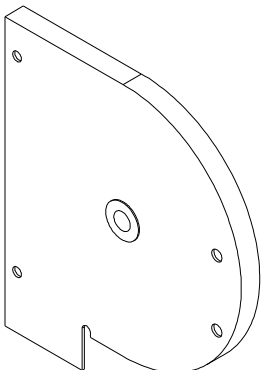
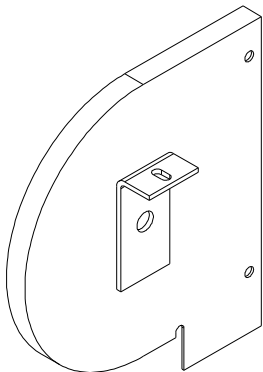
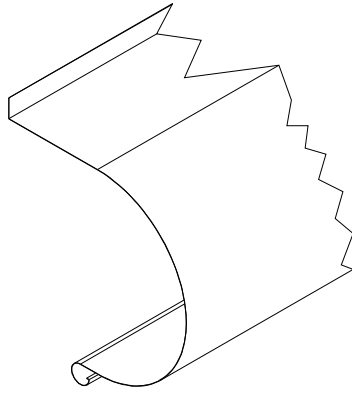
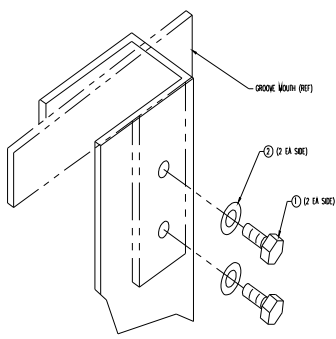
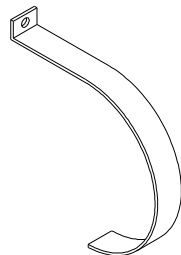
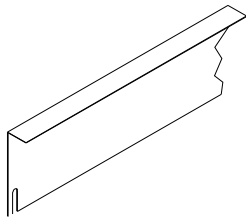
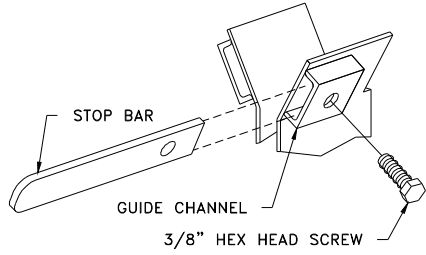
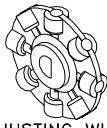
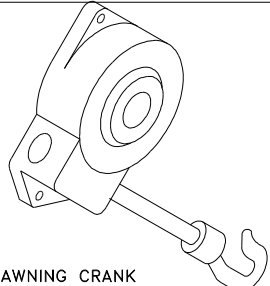
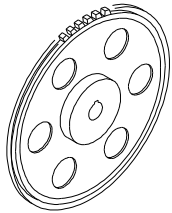
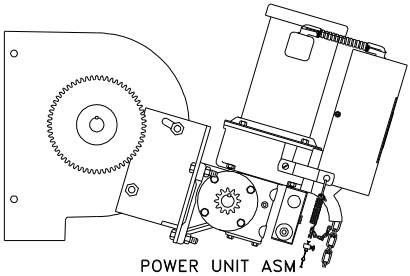
		
OP. BRACKET ASM	ADJUST. BRACKET ASM	FRONT HOOD
		
GROOVE MOUTH ("G" GUIDES)	HOOD STRAP( WHEN REQD)	BACK HOOD (UNDER LINTEL ONLY)
		
BOTTOM BAR STOPS (3 ANGLE GUIDES)		ADJUSTING WHEEL
		
AWNING CRANK	MAIN GEAR	POWER UNIT ASM



# Section 3 - Supplied Parts List

## Miscellaneous Components and Hardware

Also included is a bag of hardware with a packing slip to show where each piece is used. Below is an example including a ruler for your convenience:

No/ Door	Part Number	Description	Where Used
6	801-0350-50	1/2"-13 x 1-1/2" HH Cap Screw	Brackets to Guides
6	802-0004-05	1/2"-13 Hex Nut	Brackets to Guide
18	805-0100-04	3/8" x 3-3/4" Stud Anchors	Guide to Wall
5	801-1070-05	1/4"-20 x 1-1/2" RHMS	Hood to Wall
5	805-0129-04	1/4" x 1" Expansion Shield	Hood to Wall
5	804-0002-05	1/4" Flat Washer	Hood to Wall
10	803-1807-05	1/4" x 1/2" Self-Tapping Screws	Hood to Brackets/Strap
4	801-2808-05	3/8"-16 x 3/4" Hex Hd Grade 5	BB Stops to Guides
10	801-0274-05	5/16"-18 x 1" HHCS	Top Slat to Ring
10	802-0031-05	5/16"-18 Square Nut	Top Slat to Ring
10	804-0025-05	5/16" Flat Washer	Top Slat to Ring

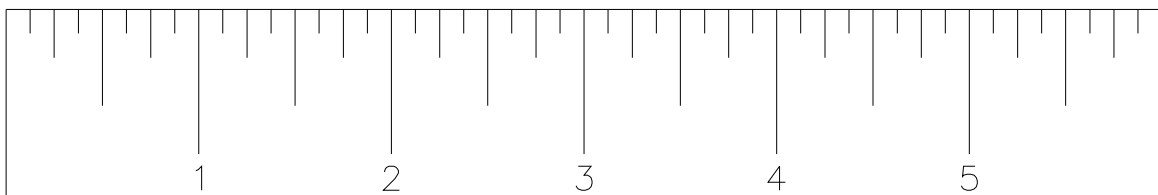

# Step 1 : Opening Checks

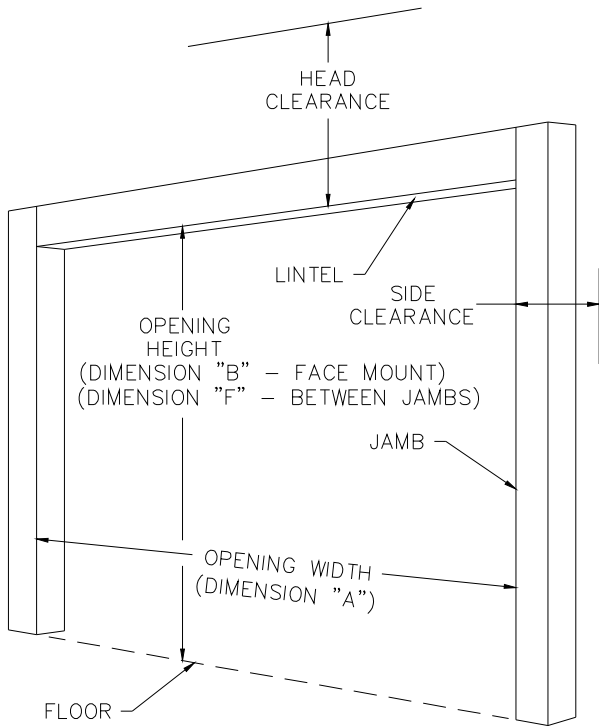

Figure #2

Refer to Figure 3. Check the opening width "A" and the opening height "B" or "F" and compare with the installation drawing to be sure the opening is the proper size for the door. Any variations in the actual opening width or height, or plumbness of the jambs is to be disregarded when installing the guides. Verify the clearances available meet or exceed those given on the installation drawing.

**NOTE:** Unpack and lay out all door components (prior to leaving for the job site, if possible) and review the following:

1. Does barrel hand of operation match the required hand on the drawings?
2. do guide mounting angles match the required arrangement for masonry or steel?
3. Are all "extras" included such as safety edge, weather stripping, etc.

If no is the answer to any of these questions, stop and check with the factory for clarification before proceeding.

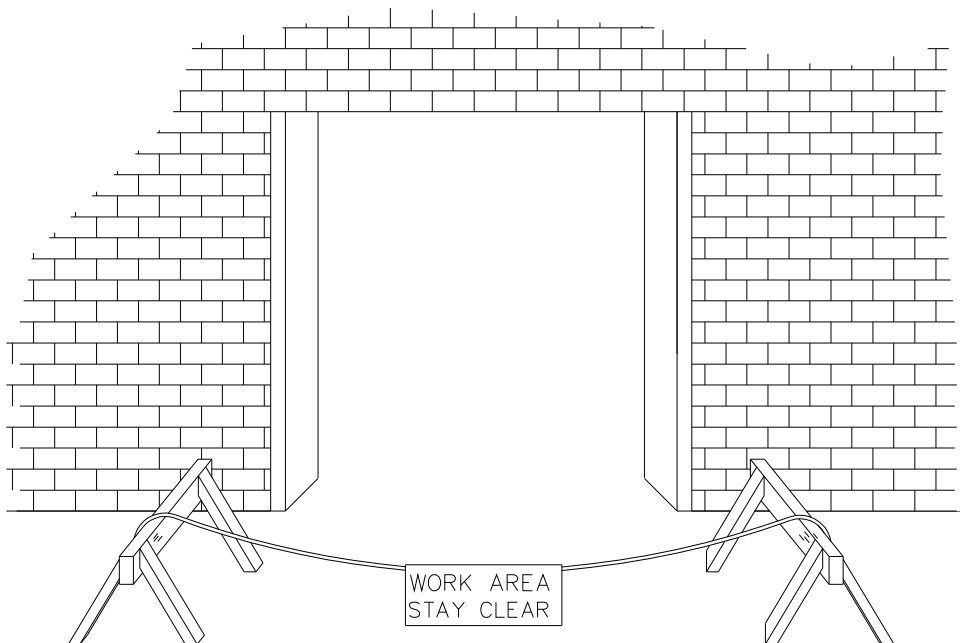

**Rope off the opening prior to beginning work!**

# Step 2 : Guide Mounting

## 2a. Face Mounted Door (Brackets Above Lintel) (skip to strp 2b if door is “between jambs mounted” ie., brackets below lintel)

Refer to Figure #4 obtain the "C" dimension from the installation drawing on the line provided below. With the guides on the floor, measure the distance from the inside of the left guide to the centerline of the slots on the wall angle (dimension "M") and record below. Repeat for dimension "M" for the right guide and record below. On masonry jambs (with mounting leg out, or "Z" guides), add both "M" dimensions to the "C" dimension to obtain the bolt line ("BL") dimension. On steel jambs (with the wall mounting leg turned in, or "E" guides), subtract both "M" dimensions from the "C" dimension to obtain "B.L".

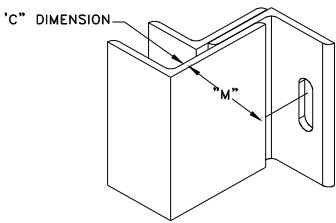

Figure #3

"C" Dimension (from Dwg)	_____
"M" (Left Guide)	_____
"M" (Right Guide (+ Masonry jamb; - Steel jamb)	_____
Bolt line (BL)	_____

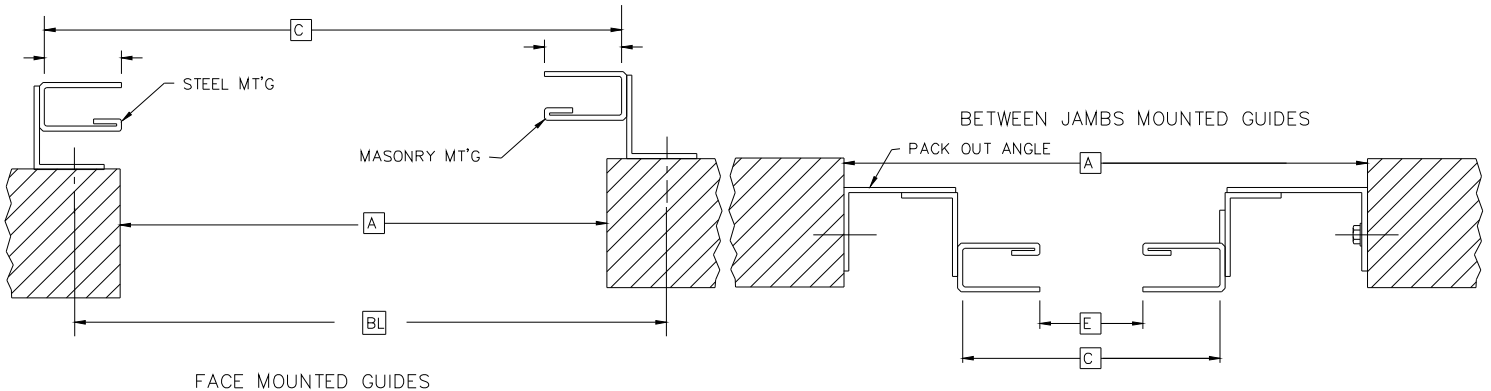

Figure #4

To transfer the location of the bolt line ("BL") for the guide mounting bolts on the wall, first locate and mark the center of the opening above the lintel (see Figure #4A). Divide BL in half ( $BL/2$ ) and measure this distance either side of the opening center mark to obtain the bolt line on each jamb. Drop a plumb line down and make a second mark on the wall at the bottom of each jamb. Using a chalk line, snap a vertical line the length of the "F" dimension (see installation drawing).

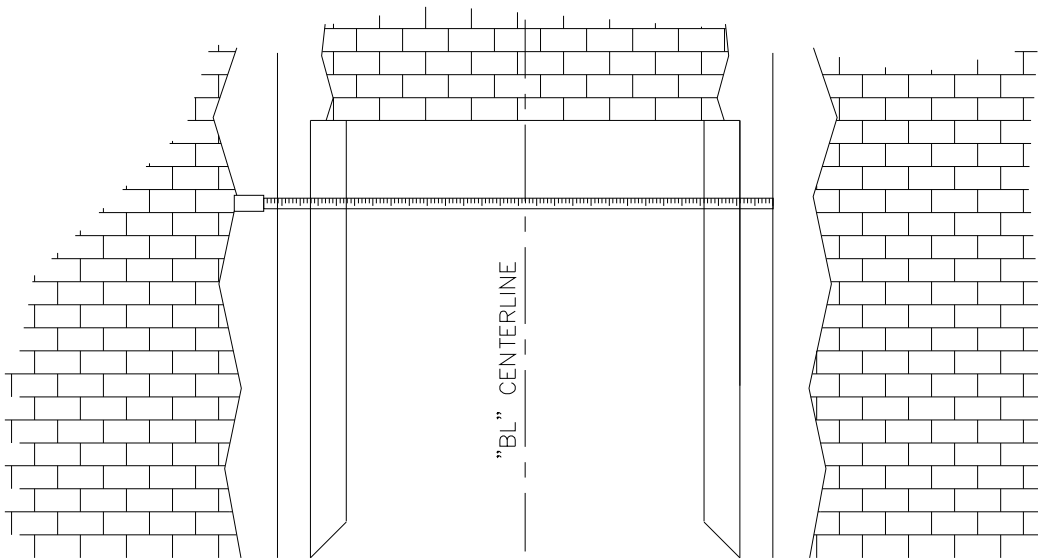

FIGURE #4A

**WARNING-** THE GUIDE ASSEMBLIES ARE EXTREMELY HEAVY. Persons with back problems or other physical conditions which may limit them from lifting heavy objects should not perform this next step.

Below is a \*chart listing the weight (in pounds) for each jamb's guide assembly to be used for reference in handling:

Opening Width	Opening Height							
	10	12	14	16	18	20	22	24
Up to 12'	65	77	89	146	164	182	200	218
12'-13'6"	76	90	128	146	164	182	200	218
13'6" - 16'	92	109	128	146	164	182	200	218
16' - 20'	120	143	165	187	210	232	254	277
20' - 24'	149	176	204	232	260	288	316	344

This chart is based on standard products. Special guide angles or unusual mounting conditions do not apply. In event that the opening falls in between sizes, use the next higher size up.

Next temporarily but securely clamp or hold the guides to jamb, carefully aligning center of holes along the chalk "bolt line".

**NOTE: IF FLOOR IS NOT LEVEL, MARK ON JAMB WHERE FLOOR SHOULD BE IF IT WERE LEVEL. SHIM GUIDE TO THIS MARK PRIOR TO SCRIBING GUIDE HOLE LOCATIONS.**

After determining guides are plumb, level and properly spaced, scribe the location of the guide mounting holes on each jamb.

Remove the guides and drill (or tap) the appropriate size mounting holes for the fasteners provided (listed as “Guide-to-Wall” on hardware shipping list) at each hole location.

Attach the back groove mouth or stop bar (closest to the wall) to the top of the guide before attaching guides to the wall. File away any burrs to form a smooth junction between guide and groove mouth.

**NOTE: DO NOT** attach the front groove mouth at this time, as it will prevent the bottom bar from passing through the top of the guides.

If 3-angle guides have been dis-assembled For ease of erection, be sure to re-assemble And maintain all relative dimensions (such As groove depth, “C” dimension, etc.)

Install top and bottom bolts in both guides with hardware provided. Check the “C” dimension and compare with the installation drawing.

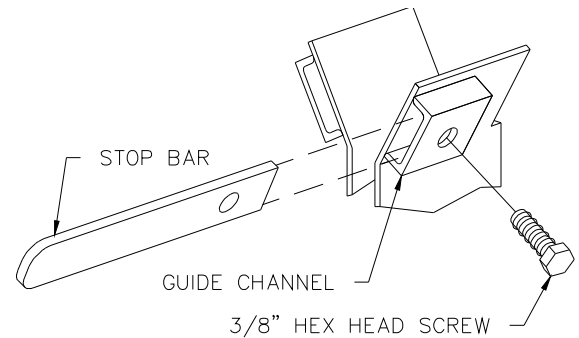
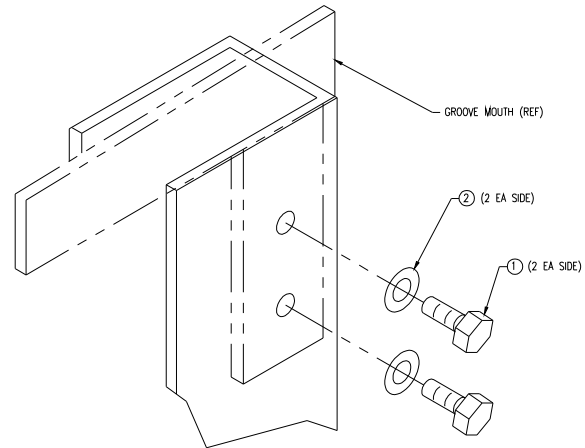

Figure #5

**IMPORTANT!** THE GUIDE TO GUIDE DISTANCE, OR “C” DIMENSION ON THE INSTALLATION DRAWING MUST BE HELD. (See Figure # 4.)



Figure #5A

Using a string and a level, ensure that the guides are parallel to each other, shimming if necessary to achieve vertical and horizontal leveling. Now install the remaining bolts.

**IMPORTANT!** USE OF ANY OTHER TYPE FASTENER THAN THOSE PROVIDED MUST BE APPROVED BY MANUFACTURER OR LOCAL BUILDING AUTHORITY AND CANNOT BE OF A LESSER DIAMETER OR GRADE.

## 2b. Between Jambs Mounted Doors (Bracket Under Lintel):

Note that a fourth angle (sometimes called the “packout” angle) is provided with the guide assembly (see Figure #5). Unbolt this angle from the guide assembly (if supplied by factory).

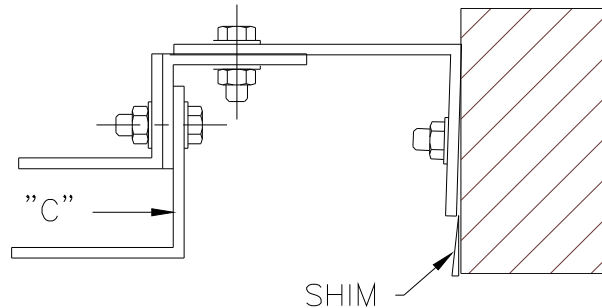

**NOTE:** The extra “packout” angles are seldom the same size (right and left) and after unbolted must be re-attached to the correct side. Mark “L” or “R” on the angle leg that mounts to the wall to avoid confusion later.

Figure #6

Next, determine the location of the “boltline” (BL) (For the guide mounting bolts on the wall, (Follow this procedure for either masonry or steel jambs.) Mark the top of the jamb where the BL is to be located and drop a plumb line to the bottom point there, and snap a chalk line between these two points. Repeat this procedure for the opposite jamb making sure the BL is exactly the same distance into the opening.

Choose one “packout” angle to be used as a template. Temporarily clamp the angle in the proper jamb (ie, left angle in left jamb) aligning the center of the holes with the chalk line. After determining that the “packout” angle is plumb, level and properly spaced into the opening, carefully scribe the location of each guide mounting hole on the jamb.

Repeat this procedure for the opposite side making sure that the angle is located at exactly the same distance into the opening. Remove the packout angle and drill the appropriate size mounting holes for the fasteners provided (listed as “Guide-to-Wall” on hardware shipping list.

Re-attach the packout angle to the appropriate guide assembly. Next attach the back groove mouth or stop bar (furthest from the coil assembly) to the top of each guide. **NOTE: DO NOT** attach the front groove mouth or stop bar at this time, as it will prevent the bottom bar from passing through the top of the guides. Install both the guide assemblies on each jamb starting with the top and bottom bolts using the hardware shimming if necessary to achieve vertical and horizontal leveling (see Figure # 6). Now install the remaining bolts.

**IMPORTANT!** REFER TO THE INSTALLATION DRAWING PROVIDED FROM THE FACTORY. THE CORRECT “C” DIMENSION MUST BE HELD, AS THE IMPROPER “C” DIMENSION MAY PREVENT PROPER OPERATION OF THE DOOR. (See Figure #4)

**IMPORTANT!** USE OF ANY OTHER TYPE FASTENER THAN THOSE PROVIDED MUST BE APPROVED BY MANUFACTURER OR LOCAL BUILDING AUTHORITY AND CANNOT BE OF A LESSER DIAMETER OR GRADE.

## 2c. Alternate Welding of Guides to Steel

On jambs with steel channel, welding of the guides is an approved method of installation providing it is done following the procedures set forth in this manual, and achieve the equivalent strength of each omitted bolt. Refer to Figure # 7 for proper welding method of guides to steel jambs.

**IMPORTANT! THE INSTRUCTIONS LISTED BELOW MUST BE FOLLOWED CLOSELY. FAILURE TO DO SO MAY CAUSE THE DOOR TO BE INOPERATIVE IN THE EVENT OF A FIRE!**

**IMPORTANT! THE “C” DIMENSION MUST BE CAREFULLY CONFIRMED TO BE CORRECT BEFORE WELDING IS PERFORMED.**

Option 1 :Welding on outside  
of wall angle.

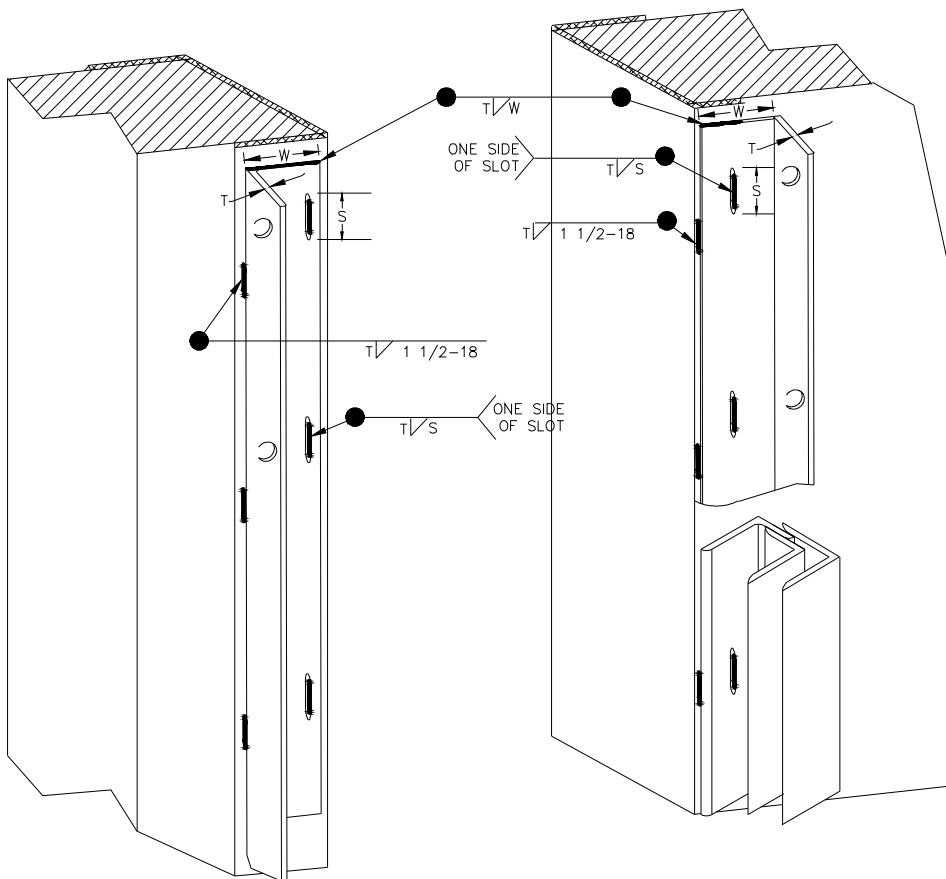

Use minimum 60xx electrodes. All welding is to be done “vertical up” (i.e. starting from the base of an individual weld and welding upwards) in accordance with A.S.T.M. procedures. Use fillet welds based on the information provided and in accordance with the local building authority.

Option 2 : Welding on inside  
of Wall angle.

Figure #7

# Step 3: Attaching Curtain to Barrel Assembly

**NOTE:** If door is to be mounted outside, slats are arranged to provide watershed (Z) unlike watershed (Y) for those mounted inside. See Figure #8 below to confirm your curtain has the correct watershed. For larger doors or preference see “Optional Method of Attaching Curtain to Barrel” on page 10).

Lay out the curtain and barrel assembly in front of the opening. Note the green sticker located on the end of the barrel (see Figure#9). This sticker will indicate the right and end, the direction the curtain uncoils to the door, and the spring turns required to balance the door.

Orient the barrel with its right hand end on the Right side of the opening. Center the top slat of the curtain with the barrel assembly and connect it to the barrel rings as shown in Figure #10. If rings are not provided, attach the top slat to bare pipe at weld nut locations **NOTE** :It is important that the bolts be tight (slats may distort some when tightening).

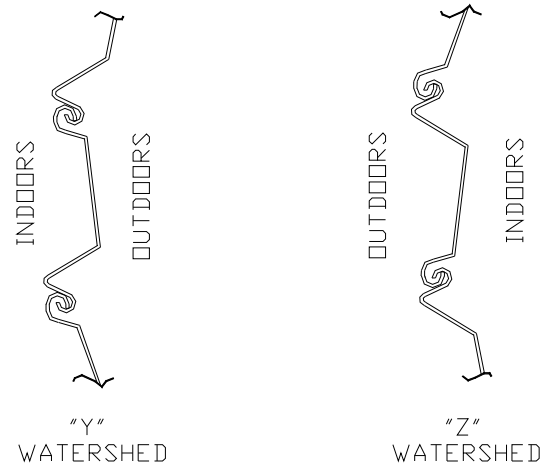

FIGURE 8

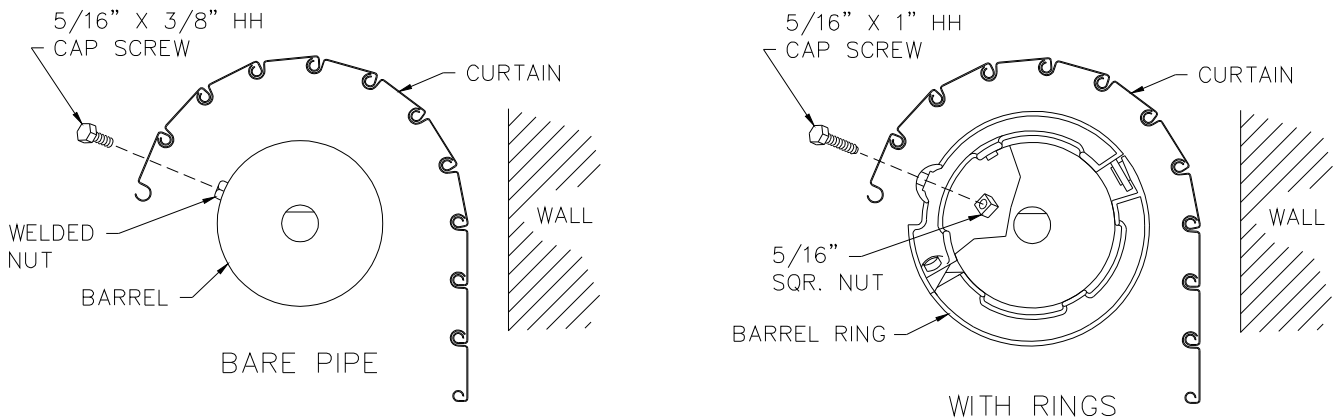

Figure #9

**IMPORTANT!** LONGER BOLTS THAN PROVIDED MUST NOT BE USED, AS THEY MAY INTERFERE WITH THE INTERNAL PARTS OF THE BARREL.

**CAUTION-** ALL PARTS (EXCEPT KEYS ) ARE DESIGNED FOR A SLIP-FIT. FORCING PARTS TOGETHER CAN CAUSE DAMAGE RESULTING IN MALFUNCTION OF DOOR.



For smaller doors, slide the operating and adjusting brackets onto the barrel shaft extensions and place the brackets on wood blocks as shown in Figure 11. Install the adjusting wheel onto the barrel shaft extension (with the flat) as shown in Figure #9 and lock it in place with a cotter pin. Apply tension to roll the curtain onto the pipe.

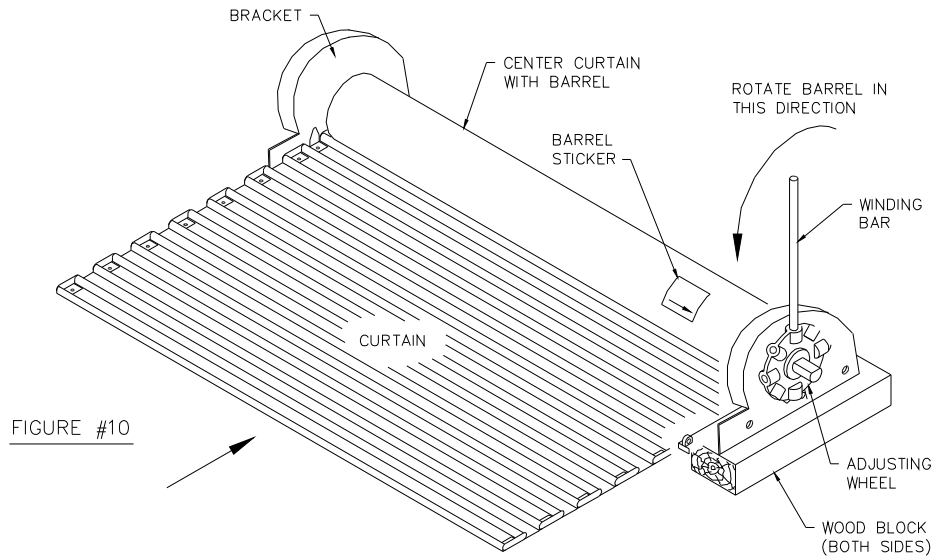

FIGURE #10

For larger doors, see optional suggested methods below for lifting curtain into position.

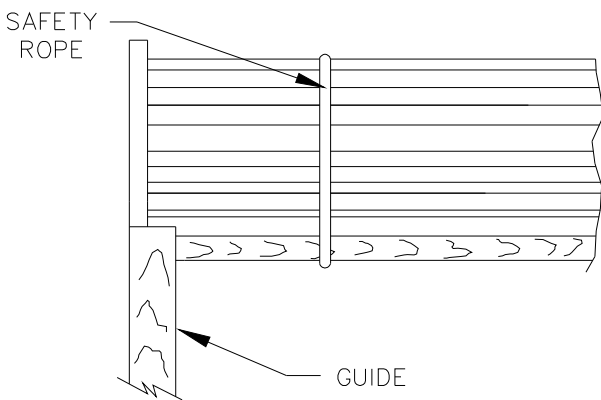

Figure #11

**NOTE: TAKE PRECAUTIONS TO PREVENT THE CURTAIN FROM BEING DAMAGED WHEN SLIDING ON THE FLOOR.**

Tie a rope around the coil to keep the curtain from uncoiling.

**NOTE: GENERALLY THE SPRINGS ARE CLOSER TO THE ADJUSTER SIDE MAKING THE COIL ASSEMBLY HEAVIER AT THAT END.**

Sling the coil and barrel assembly near its balance point for lifting into place.

# Step 4: Attaching Brackets to Wall Angles

Determine the best method of lifting the curtain coil and brackets to prevent damage to the curtain during installation. Refer to optional suggested methods below.

**⚠️ WARNING-BRACKET AND CURTAIN ASSEMBLY ON LARGER DOORS, PARTICULARLY WITH AN OPERATOR, CAN BE EXTREMELY HEAVY. PERSONS WITH BACK PROBLEMS OR OTHER PHYSICAL CONDITIONS WHICH MAY LIMIT THEM FROM LIFTING HEAVY OBJECTS SHOULD NOT PERFORM THE NEXT STEP.**

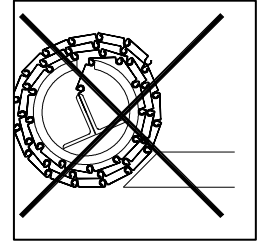

Refer to the following table to verify that the lifting capacity of the hoist (or fork truck) exceeds the weights given for the barrel and curtain assemblies:

Model	Formula	Factor	Door	Barrel
924	$W \times (H+1) \times$	2.2	2" slat, 24 gauge steel	0.52 X Curtain Wt
922	$W \times (H+1) \times$	2.65	2" slat, 22 gauge steel	0.52 X Curtain Wt
822	$W \times (H+1) \times$	2.65	3" slat, 22 gauge steel	0.52 X Curtain Wt
820	$W \times (H+1) \times$	2.95	3" slat, 20 gauge steel	0.52 X Curtain Wt
818	$W \times (H+1) \times$	4.05	3" slat, 18 gauge steel	0.52 X Curtain Wt
825C	$W \times (H+1) \times$	4.8	Insulated, 24 gauge steel	0.52 X Curtain Wt
823C	$W \times (H+1) \times$	5.0	Insulated, 22 gauge steel	0.52 X Curtain Wt
821C	$W \times (H+2) \times$	5.55	Insulated, 20 gauge steel	0.52 X Curtain Wt
819C	$W \times (H+2) \times$	6.25	Insulated, 18 gauge steel	0.52 X Curtain Wt

where W=door width (feet) and H=door height (feet)  
 (ex: for an 8x8 924 door, Curtain Wt=8x9x2.2=158.4;  
 Barrel=0.52 x 158.4=82.4)

Lift the curtain coil and brackets to the bracket mounting holes provided in the wall angle. **NOTE:** Take care not to drag coil assembly over exposed groove mouth bolts. Should these be exposed, cover them to prevent damage to screws and/or curtain while lifting coil in place.

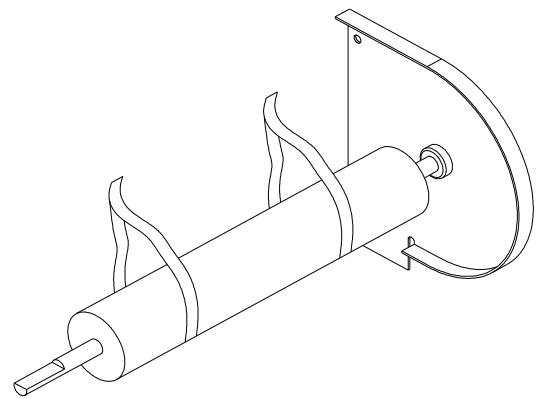

**Figure #12**

BRACKET IS MOUNTED TO THE WALL ANGLE ABOVE HERE

Make sure the bracket is positioned outside the G-guide wall angle or outside the 3-angle guide wall angle (Figure #13).

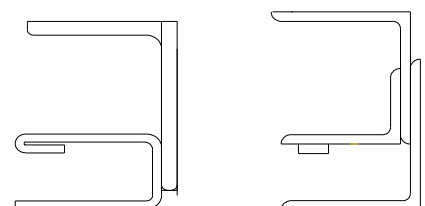

**Figure #13**

Bolt the bracket and guides together as shown in Figure #13A.

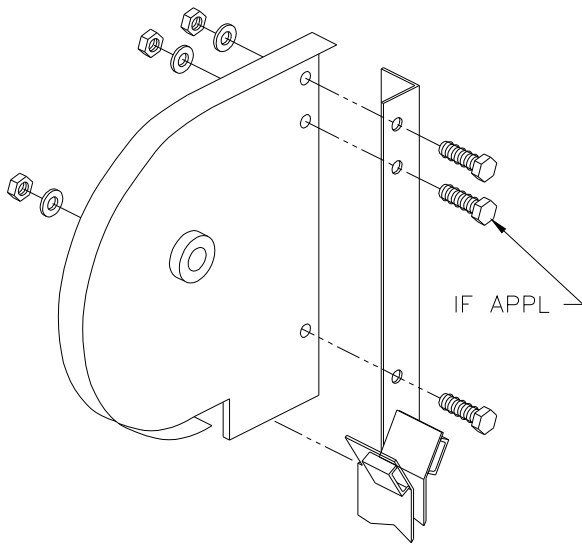

**HINT:** It is generally easier to insert the bottom bracket hole first, but do not tighten the bolt yet. As the coil is lifted higher, the brackets will pivot on this bolt for easily locating the top bracket bolts. Now tighten all bracket bolts.

**IMPORTANT! THE BOLT HEADS MUST BE IN THE INSIDE (THREADED SECTION OUT) TO PREVENT INTERFERENCE WITH THE OPERATION OF THE COIL.**

**⚠ WARNING-DO NOT REMOVE HOIST SLING UNTIL ALL BRACKET BOLTS ARE INSTALLED AND SECURE, OTHERWISE CURTAIN COIL COULD FALL STRIKING SOMEONE AND CAUSING SEVERE INJURY OR DEATH.**

**Figure #13A**

**⚠ WARNING-DO NOT LET THE CURTAIN ROTATE IN FREE FALL. NO TENSION HAS YET BEEN APPLIED TO THE SPRINGS. FREE FALLING CURTAIN COULD STRIKE SOMEONE CAUSING SEVERE INJURY OR DEATH.**

Loosen the safety rope(s) to let the curtain uncoil until the bottom bar is a few inches below the top of the guides. Block the curtain in place to prevent it from dropping. Attach the front groove mouths (or stop bars) to the top of each guide.

Optional Method of Attaching Curtain to Barrel:

For some larger service doors, the combined weight of the coil and barrel may be too heavy to lift into place as one item as treated above. The optional method below describes how to lift each on separately.

Attach the operating bracket to the guides as described above. Slide the adjusting bracket onto the barrel's tension shaft extension (with the flat) and lift the barrel assembly and adjusting bracket into place with sling. Feed the operating shaft through the operating bracket already attached, and proceed to attach the adjusting bracket to the guides.

**HINT:** The tensioning end of the barrel contains most of the spring and is generally the heavier end, so sling the barrel accordingly to best balance the load.

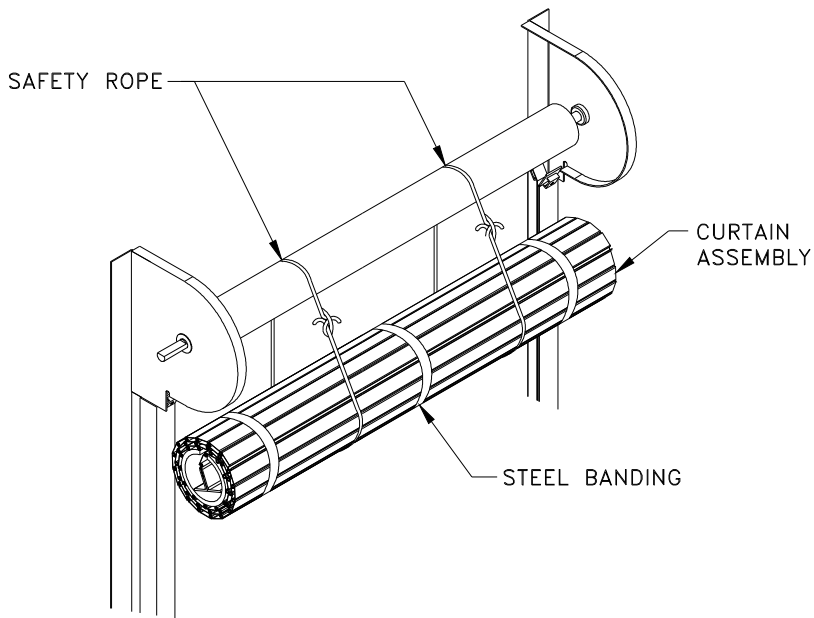

FIGURE #14

Choose two equal lengths of rope of adequate strength to support the coil's weight. Tie a large loop in these ropes around each end of the barrel about  $\frac{1}{4}$  way in from each end of the barrel so as to cradle the coil (see Figure #14). The coil and barrel should be separate by a minimum of 18" and the coil should be rolled to have the top attachment slats exposed.

Begin to rotate the barrel in the direction to raise the curtain. The rope loops will consequently uncoil the curtain. When sufficient curtain has been untiled, attach the top slat to the rings (or bare pipe) as described earlier. With the top slat attached, continue to completely unroll the curtain in a similar fashion.

HINT: Using the AW to wind the coil around the barrel may prove easier than manually turning the barrel.

**⚠ WARNING : DO NOT LET THE CURTAIN ROTATE IN FREE-FALL. NO TENSION HAS BEEN APPLIED TO THE SPRING. FREE FALLING CURTAIN COULD STRIKE SOMEONE CAUSING SEVERE INJURY OR DEATH.**

Carefully untie the rope(s) securing the coil. While restraining the coil from turning freely, feed the bottom bar into the top of the guides allowing the curtain to advance approximately 6" to 12". Block the bottom bar so it cannot travel beyond this point. Proceed to attach the front groove mouths (or bottom bar stops) to the top of both guides.

## STEP 5: Applying Tension

### 5a. Outside AW:

The amount of initial revolutions (IR's) as indicated on the installation drawing and on the barrel "rev tag" is the **THERETICAL STARTUBG POINT** for the required spring tension. In most cases this figure is correct, but due to variations in steel, springs, friction, etc., slight adjustments may be required.

**⚠ CAUTION- ALWAYS WIND TENSION WHEN THE DOOR IS IN THE UP POSITION. THE SPRINGS ARE UNDER THE LEAST AMOUNT OF TENSION AT THIS POINT.**

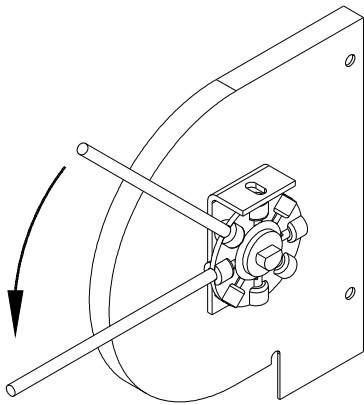

By hand, rotate the adjusting wheel (AW) slightly in both directions to determine the neutral point of the tension shaft. Mark the hole on the AW which is nearest to the retaining lug on the tension bracket. Using approved winding bar (see tool list in front of manual), insert the two winding rods securely into the holes in the AW as shown in Figure #14.

**NOTE: TENSION IS APPLIED IN THE DIRECTION AS THE DOOR WOULD TURN AS IT COILS UPWARD (OPPOSITE THE DIRECTION OF THE ARROW ON THE "REV TAG").**

Figure #15

**⚠ WARNING -WINDING BAR MUST FIT SNUGLY INTO HOLES IN ADJUSTING WHEEL. DO NOT USE LOOSE FITTING BARS OR SCREWDRIVERS WHICH COULD SLLIP OUT AND CAUSE SEVERE INJURY OF DEATH. STAND TO ONE SIDE-NEVER WIND THE SPRING DIRECTLY IN FRONT OF YOU.**

Apply the initial revolutions (IR's) marked on the rev tag and installation drawing counting from the mark on the AW made earlier. The IR's are the required number of turns (of the spring) to hold the curtain in the open position.



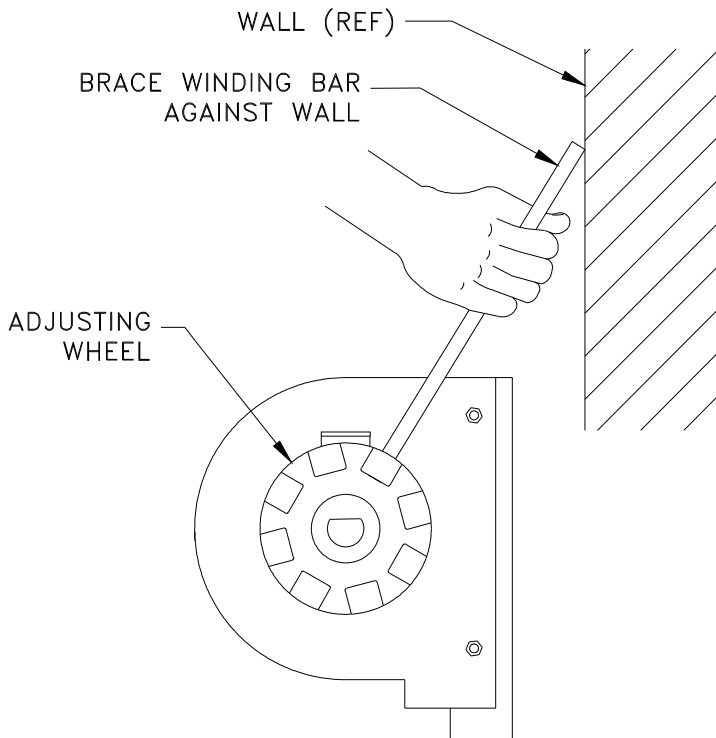

HINT: If installation permits, use wall above bracket as brace for winding rod for a sage, hands-free procedure of installing the AW pin (see Figure #15).

**⚠ WARNING- EXERCISE EXTREME CAUTION. DO NOT RELEASE THE ADJUSTING WHEEL. CONTACT WITH RAPIDLY ROTATING WHEEL OR EXPELLED WINDING ROD CAN CAUSE SEVERE INJURY OR DEATH.**

While holding the winding bar firmly in one hand, insert the AW pin with the other hand through the lug in the bracket and into the hole in the AW to lock the AW at the desired number of revs. Remove winding rods. (See Figure # 16).

**IMPORTANT!** APPLY ONLY ENOUGH TENSION TO HOLD THE DOOR IN THE UP POSITION AGAINST THE BOTTOM BAR STOPS. THIS IS THE OPTIMUM SETTING. TOO MUCH TENSION WILL PREVENT THE DOOR FROM COMPLETELY CLOSING.

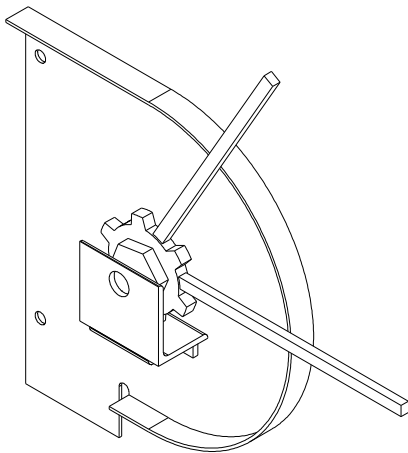

### 5b. Inside AW:

See Figure #16 for instructions in the winding of an inside AW, should the door require one. The curtain must be unrolled to access the AW. Using  $\frac{1}{2}$ " square winding bars, apply the total revs indicated on the rev tag. Test and adjust as required for proper balance.

**⚠ WARNING- DO NOT LET THE CURTAIN ROTATE IN FREE-FALL. NO TENSION HAS BEEN APPLIED TO THE SPRING. FREE FALLING CURTAIN COULD STRIKE SOMEONE CAUSING SEVERE INJURY OR DEATH.**

**Figure #16**

**⚠ WARNING-THE INSIDE AW CAN ONLY BE ACCESSED WITH THE CURTAIN DOWN. EXERCISE EXTREME CAUTION AS TOTAL TENSION MUST BE APPLIED. DO NOT RELEASE THE ADJUSTING WHEEL. CONTACT WITH RAPIDLY ROTATING WHEEL OR EXPELLED WINDING ROD CAN CAUSE SEVERE INJURY OR DEATH.**

### 5c. Compound AW (sprocket reduction):

See Appendix E, "Compound Tension Adjuster Assembly", for instructions to wind a compound AW. With the curtain up, wind the initial revs with  $\frac{3}{4}$ " winding bars by counting the large sprocket.

### 5d. Inside Dead-Tension Adjuster (inside holder):

See Figure #17 for instructions to wind an inside dead-tension adjuster. The curtain is lowered in the guides but not bolted to the barrel. The tension shaft is bolted to the holder on the bracket. The curtain, crank, hoist or motor is used to turn the pipe in the direction shown to wind the total revs. Then, fasten the curtain to the barrel.

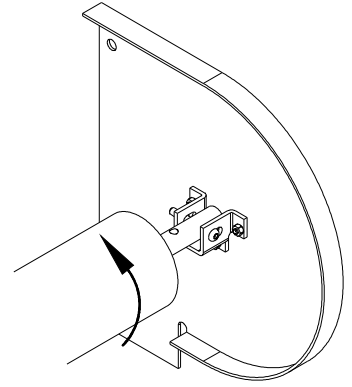

## STEP 6: Testing Door Balance

It is generally a good practice to have on hand a pair of rods to use as a gage for the guide opening ( $11/16$ " min to  $3/4$ " max for 2" slats, and  $1-1/16$ " min to  $1-1/8$ " max for 3" slats). Sliding the rods down the entire length of the inside of the guides will reveal any pinched areas where the rods will not pass. Use the pair of rods in a scissors fashion to pry the guide to the required opening dimension if required.

With the adjusting wheel locked, operated the door through several cycles to check door balance if possible. If the door does not balance properly and requires further spring adjustment, repeat the procedure for "Applying Tension" to add or remove spring tension. Ideally, the door should have sufficient spring tension to just allow the door to stay up in the open position and no more.

**IMPORTANT! INCREASING THE INITIAL TENSION WILL REDUCE EFFORT BUT CAN PREVENT DOOR FROM COMPLETELY CLOSING.**

## Methods Of Operation Of Service Doors

- Manually Operated Door (Push-up):  
No operator of any kind is required. The door is opened and closed manually by pushing up and down on the bottom bar (taller doors may require a rope or hook to reach the bottom bar in the open position).
- Chain Hoist: Install the hoist as shown in Figure #18.
- Awning Crank Operate: Install the awning crank as shown in Figure #19.
- Motor Operated:  
Bracket Mounted: Install the power unit support and operator as shown in Figure #20

Thru-wall Mounted: See Appendix E for instructions.

**⚠ WARNING-MECHANISM AND GEARS MOVE FREELY AND QUICKLY. TO AVOID SEVRE INJURY OR DEATH, KEEP HANDS, ARMS AND CLOTHING FREE OF MOVING MECHANISSMS AND MESHING GEARS.**



# Chain Hoist Operated Service Door (LH Shown, RH Opposite)

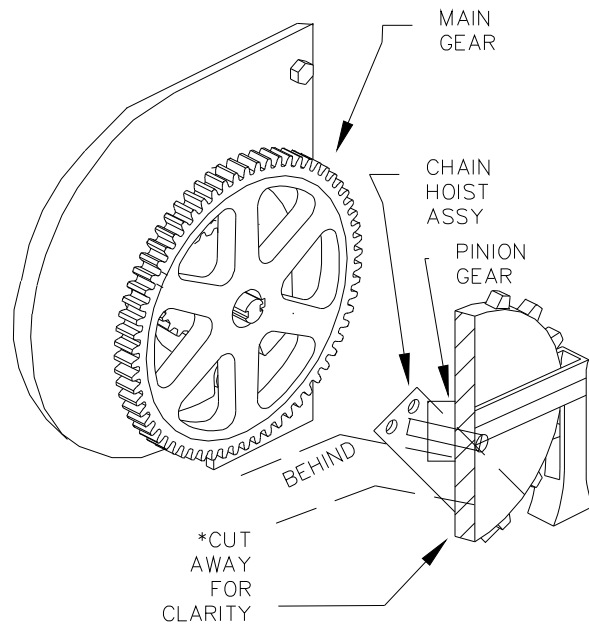

Figure #18

# Awning Crank Operated Service Door (LH Shown, RH Opposite)

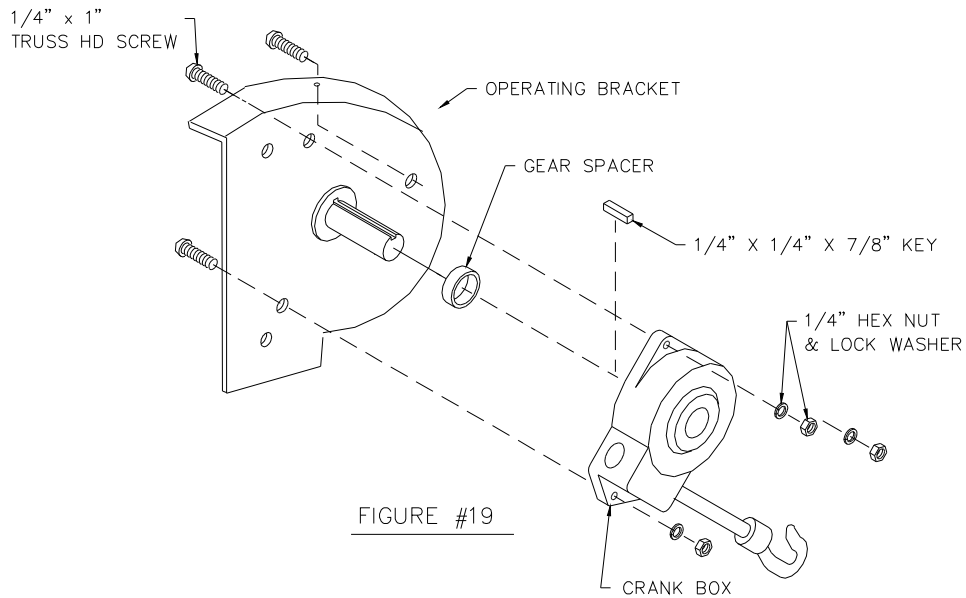

Figure #19

# Bracket Mounted Motor Operated Service Door (LH Shown, RH Opposite)

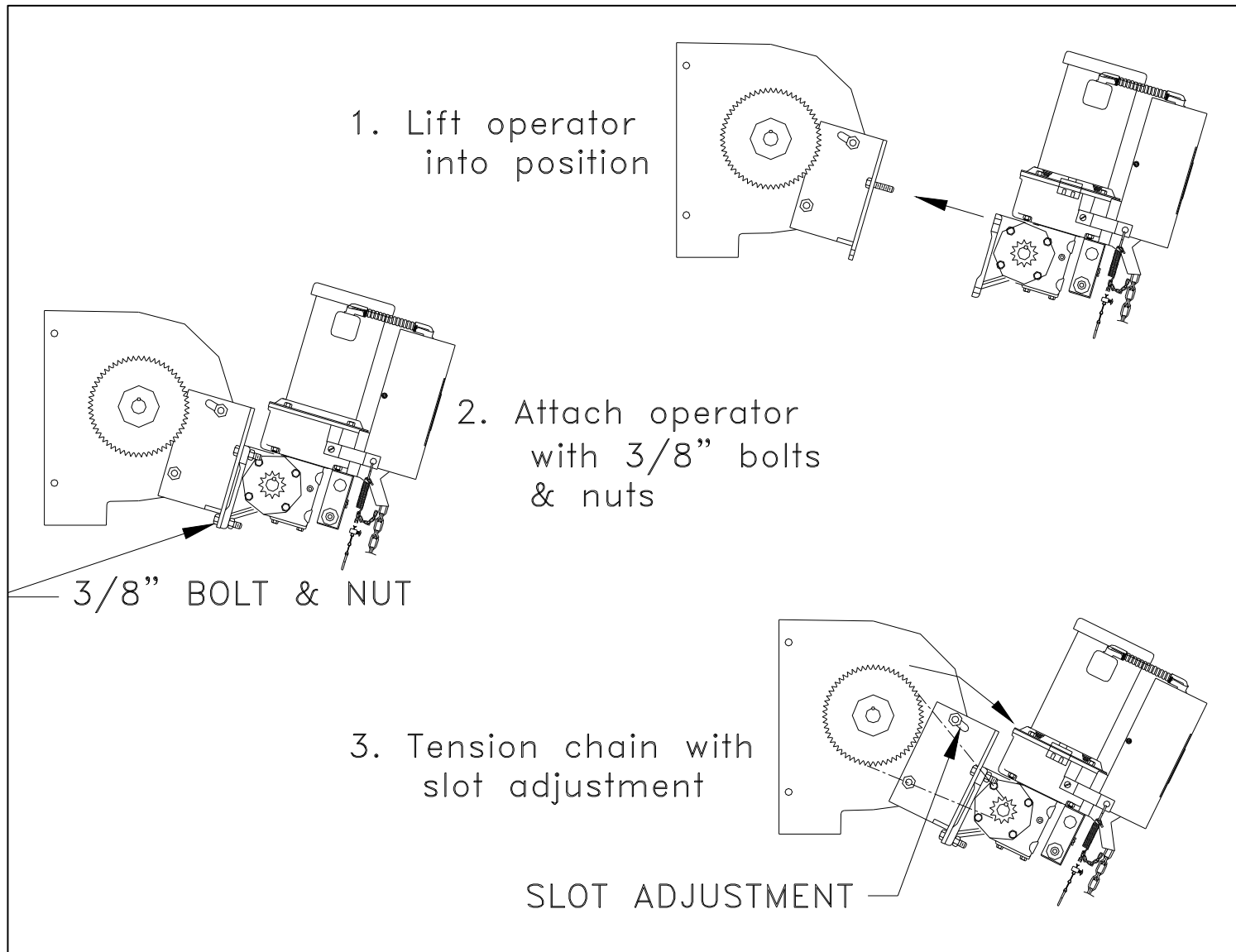



Figure #20

**⚠ WARNING: GETTING HANDS CAUGHT IN SPROCKETS OR CHAIN CAN CAUSE SEVERE INJURY. A GUARD OR COVER MUST BE INSTALLED IF THESE COMPONENTS ARE WITHIN REACH. COVERS ARE AVAILABLE AS OPTIONS FROM THE FACTORY.**

# Step 7: Installing Hoods, Hood Supports & Housings

## 7a. Hood (and Hood Support) Attachment:

**HINT:** Lower the door to offer the maximum clearance between the coil and the wall. Rest hood strap(s) on coil near its attachment location.

 **WARNING- DISCONNECT OPERATOR PRIOR TO WORKING NEAR OPERATOR END OF DOOR WHEN ATTACHING HOOD. SERIOUS INJURY MAY RESULT BY INADVERTENT OPERATION OF THE OPERATOR.**

When a two or more piece hood is furnished, fasten the hood support (sometimes called “hood strap”) to the wall where the hood is spliced together (see Figure #22A). It may be necessary to add structure on “open steel” type constructions-not provided by manufacturer as standard.

Raise the hood carefully over the brackets so the ends of the hood are approximately 3/16” from the outside edge of the brackets. Set the top flange tight against the wall and fasten with hardware provided (see Figure #22). Fasten the hood to the existing holes in the brackets (and supports) with self-tapping screws. If housings are required, do not tighten screws at this time, as housing must slip under hood (see step #7b). **HINT:** Use a center punch to locate position of screws in brackets before attachment.

**IMPORTANT! NEVER OMIT THE USE OF CENTER HOLE PROVIDED IN BRACKET WHEN ATTACHING HOOD. THIS REDUCES FLEXING OF BRACKETS WHEN OPERATOR IS USED.**

**IMPORTANT! IF HOOD BAFFLE IS PROVIDED, IT MUST LAY FLAT ON TOP OF COIL AND NOT FOLD OVER THE WRONG WAY. (SEE Figure #23A).**

If a back hood provided, attach it as shown in Figure #23 with self-tapping screws. Line up the edge of the back hood with the edge of the front hood before tightening screws.

## 7b. Attaching Housings:

If the door is mechanically operate and the operator is located outside and exposed to the elements, a protective housing may be provided. (see Figure #24).

 **WARNING-DISCONNECT POWER TO THE OPERATOR WHEN WORKING NEAR IT. SERIOUS INJURY MAY RESULT BY INADVERTENT OPERATION THE OPERATOR.**

Attach the housing as shown, making sure the flanges of the housing slip between the hood and bracket flange, with self-tapping screws provided.

**NOTE:** Some trim of the housing flanges may be required to offer clearance to obstructions or drive components.

Figure #25

Apply all warning labels in the appropriate locations before leaving the installation site.

Check the area for any extra parts, and be sure these were not omitted in the installation process.

Have the customer or his representative sign off on the installation, and exchange all documentation and key to locks at this time. Be sure the customer receives a copy of this manual and of the installation drawing.

If the customer is unfamiliar with the product, demonstrate the operation of the door and any optional equipment before leaving the job site.

Don't leave a mess. Clean up the area and make sure the area is secure if you're the last one to leave.

Be sure to report (in writing) to the factory any complaints or recommendations the customer may register at the completion of the installation that may have a bearing on future designs.

# Appendix A: Optional Components

The following are some examples of common options and adjustments for fire doors:

## CYLINDER LOCKS

Slide bolts are provided as a standard feature on manually operated service doors. On doors with cylinder locks on one side only, it may be necessary to remove the (2) bolts securing the lock case to the bottom bar prior to installation.

## ELECTRICAL INTERLOCKS (doors with straight slide bolts)

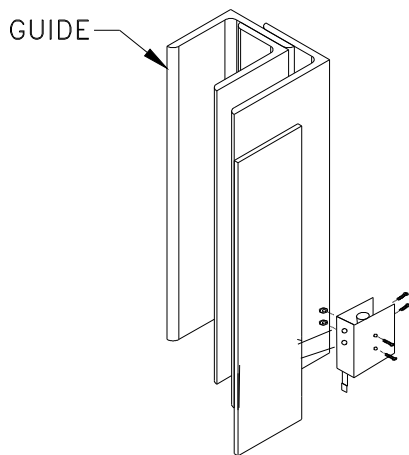

Remove the bolts and nuts holding the microswitch in the switch housing. Install the switch housing to the back of the guide with the lever pointing down using the #10 bolts and nuts provided. Re-install the microswitch (see the wiring diagram provided with the motor operator for wiring of the electrical interlocks). Verify that the slide bolts will contact the lever at the same time locking underneath the guide notch.

## ELECTRICAL INTERLOCKS (doors with offset slide bolts)

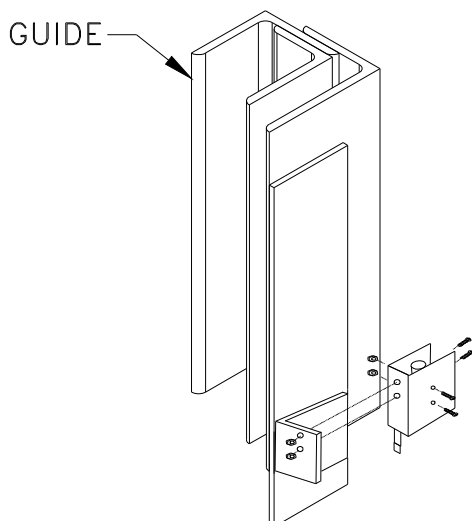

Remove the bolts and nuts holding the microswitch in the switch housing. Install the switch housing to the striker plate with the lever pointing down with the #10 bolts and nuts provided. Re-install the microswitch (see the wiring diagram provided with the motor operator for wiring of the electrical interlocks). Verify that the slide bolts will contact the lever at the same time locking underneath the striker plate.

## ELECTRICAL OR PNEUMATIC SAFETY EDGE

Mount the junction box to the outside of the guide angles using one of the assembly bolts.

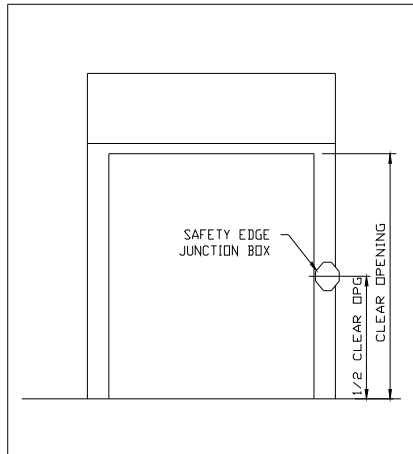

**NOTE: THE JUNCTION BOX NEEDS TO BE AT A HEIGHT OF  $\frac{1}{2}$  THE OPENING OR DOOR TRAVEL HEIGHT TO ENSURE THE COILED WIRE OR HOSE WILL REACH THE BOTTOM BAR WITH THE DOOR IN THE FULLY OPEN OR FULLY CLOSED POSITION.**

See the wiring diagram included with the motor operator for wiring of the electric or pneumatic safety edge.

## PNEUMATIC SAFETY EDGE (WITH AIR SWITCH MOUNTED ON BOTTOM BAR):

On doors with pneumatic safety edges with cable take-up reels (ie, air switch mounted on the bottom bar), it is necessary to remove the air switch prior to installation.

### REMOVAL:

Remove the (2) #10 screws and nuts securing the air switch connection box to the bottom bar. Remove the connection box.

### INSTALLATION:

Reverse the above procedures. Run wire leads from cable reel into connection box and make connection to air switch. Install air switch lid with the (4) #8 screws provided. Attach air hose to air switch lid on brass fitting.

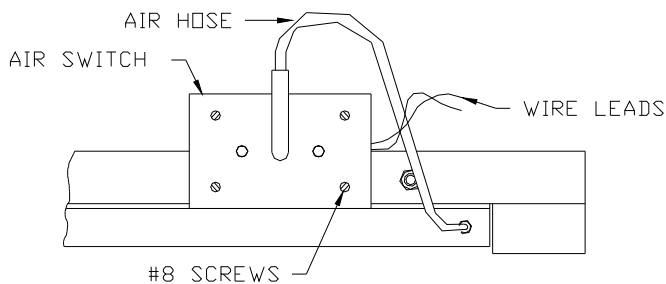
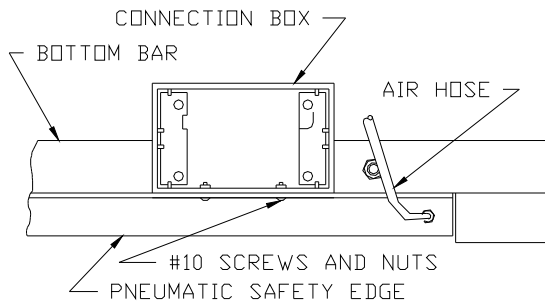





# Appendix C: Troubleshooting

The chart below is a list of possible problems with the operation of the fire door. The probable causes listed are the most common, and are not meant to include **ALL** possibilities. With the variety of the product and the field conditions, other factors may be involved. If assistance beyond this troubleshooting chart is needed, please contact your Wayne-Dalton dealer. Factory support is available to him, should it be necessary, in order to resolve your problem.

<b>TROUBLE</b>	<b>PROBABLE CAUSE</b>	<b>REMEDY</b>
Door raises hard, closes easily	Insufficient counterbalance	Increase spring tension (see Step 9)
Door closes hard, raises easily	Too much counterbalance	Decrease spring tension (see Step 9)
Door jumps up from floor	Too much counterbalance	Decrease spring tension (see Step 9)
Curtain runs to one side	Broken end-locks Barrel not level	Check and replace Check and level barrel
Door sticks when closing	Bent guide angle(s)	Inspect for bent or kinked guides. Straighten guides and check width of groove.
Door coil makes cracking sound	Bent slats	Inspect, remove and straighten or replace
Door squeaks when operating	Tight guides Dirty guides	Check alignment and distance between guides. Inspect and clean inside of guide. Do not lubricate with grease. Use WD-40 or silicone spray.
Door is difficult to raise, will not stay open	Broken spring	Remove barrel and replace spring.
Motor runs, door does not operate	Curtain jammed	Inspect and remove obstruction.

# Appendix D: Thru-Wall Power Unit Assembly

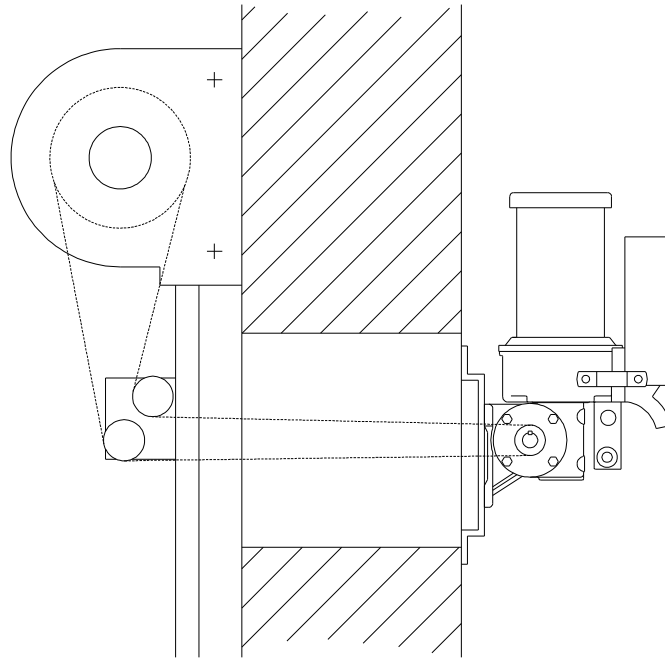

\*NOT SHOWN

06	2	1/2" LOCK WASHER
05	2	1/2"-13 HEX NUT
04	2	1/2"-13 X 1-1/2" HHCS
*03	20	SHIMS
02	1	IDLER SPROCKET & PLATE ASM
01	1	SUPPORT: MH20 SERIES,WALL MTD
ITEM	QTY	DESCRIPTION

THROUGH-WALL POWER UNIT ASSEMBLY

# Appendix E: Compound Tension Adjuster Assembly

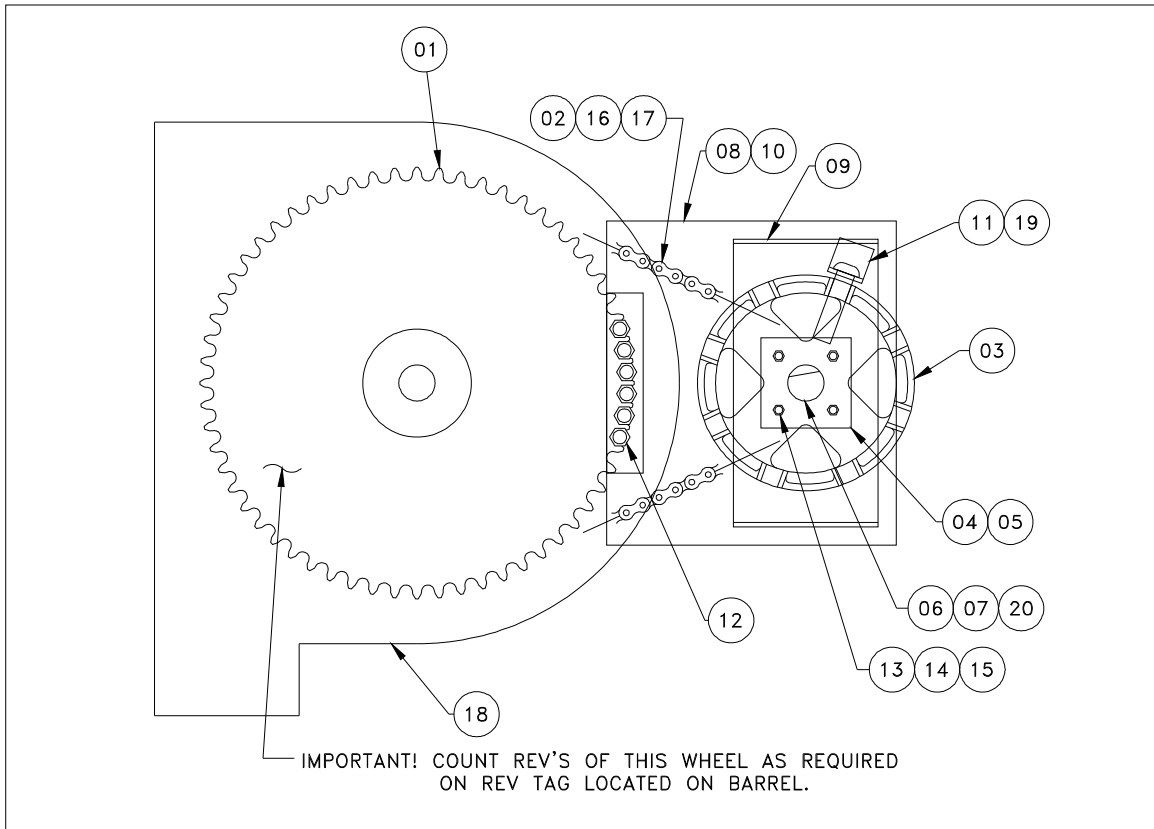

20	1	COTTER PIN : 1/4" X 2-1/4" STEEL
19	1	RIVET : 3/4" X 3-1/2"
18	1	OPERATOR BRACKET BEARING
17	AR	ROLLER CHAIN, SERIES AND LENGTH VARY
16	1	KEY : 3/8" X 3/8" X 1/4"
15	8	3/8"-16 HEX NUT
14	8	3/8" FLAT WASHER
13	8	3/8"-16 X 1-1/4" HHCS
12	6	TAP BOLT : 1/2"-13 X 2-1/2"
11	1	CLIP ANGLE : 4" X 2" X 1/4" X 2" LG
10	1	TENSION HOLDER : 2" X 10" X 1/2" BAR
09	1	SHAFT SUPPORT PLATE
08	1	MOUNTING PLATE: 16" X 16" X 3/8" STL
07	2	SHAFT COLLAR : 1-1/2" ID
06	1	SHAFT : 9-1/2" X 1-1/2" DIA (C1045)
05	2	BEARING : 1-1/2" ID
04	2	BEARING RETAINER
03	1	ADJUSTER : AW745 1-1/2" BORE
02	1	SMALL SPROCKET, 13T, 1-1/2" BORE
01	1	LARGE SPROCKET : (SIZE VARIES)
ITEM	QTY	DESCRIPTION

Use bolts (item 12) to lock large sprocket (item 1) into place after applying tension. The amount of initial turns is determined by the large sprocket.

**⚠ WARNING THE BOLTS MUST BE IN PLACE BEFORE THE DOOR IS OPERATED. THE ROLLER CHAIN WILL NOT HOLD THE WEIGHT OF THE DOOR. FAILURE TO INSTALL ALL THE BOLTS COULD RESULT IN THE CHAIN BREAKING CAUSING THE DOOR TO FALL AND COULD CAUSE SERIOUS INJURY OR DEATH**

# Appendix F : Weatherizing Instructions for Service Doors

## Vinyl Guide Weatherstrip

Apply the weatherstrip before attaching the guides to the wall, with the guides laid out on the ground. For maximum adhesion, the guides should be above 32°F (0°C) at the time of the application. The guides and the tape should be free of dirt, grease and moisture. For maximum Adhesion, wipe the guides clean with rubbing alcohol or another solvent and dry thoroughly. Next remove the waxed protective backer from the sponge tape. Apply the guide weatherstrip with the alignment nub resting along the edge of the guide. The weatherstrip should extend from just below the groove mouth or stop bars, to flush with the bottom of the guide. Press firmly one time along the entire length of weatherstrip to provide maximum adhesion-to-surface contact. Snip off the top corner of the flexible portion of weatherstrip down about 3 inches at a 45° angle.

**NOTE: THIS STEP PREVENTS THE DOOR FROM CATCHING ON THE WEATHERSTRIP AND PULLING IT OFF THE GUIDE.**

On taller doors, the weatherstrip is provided in more than one piece. It will be necessary to join the seams by either duct tape or “welding” them together with a soldering iron. Next drill a 7/32” diameter hole 3 inches from the top and the bottom of the guide as shown (it may be necessary to

install screws above and below seams when more than one piece weatherstrip is required). Attach the weatherstrip to the guide using the screws provided.

**IMPORTANT! ENSURE THAT THE SCREWS DO NOT PROTRUDE INTO THE GUIDE OPENING. THE SCREWS COULD CATCH ON THE DOOR CURTAIN CAUSING DOOR DAMAGE.**

Grind off (flush) any part of the screws that protrude into the guide opening.



**NOTICE**

**FIRE DOOR PERIODIC TEST REQUIREMENT**

This door has been installed and tested for proper operation according to procedures set forth in this manual to ensure that it performs as designed at the time of installation.

**Date** \_\_\_\_\_

**Installer**

\_\_\_\_\_  
**Phone**

**To Possessor of the Premises**

The installer has certified that this door has been properly installed, that it has been tested, and that it performs as designed at time of installation. From now on, you should have it inspected regularly and tested periodically for any subsequent damage or wear which might preclude it from closing properly in event of a fire.

**Date:** \_\_\_\_\_  
\_\_\_\_\_  
\_\_\_\_\_  
\_\_\_\_\_

**Tested By:** \_\_\_\_\_  
\_\_\_\_\_  
\_\_\_\_\_  
\_\_\_\_\_

**Fire Marshall**

Be aware that the local Fire Marshall is the final authority on the rigging and operation of a fire door. He may require steps not listed in NFPA 80 or these instructions.